

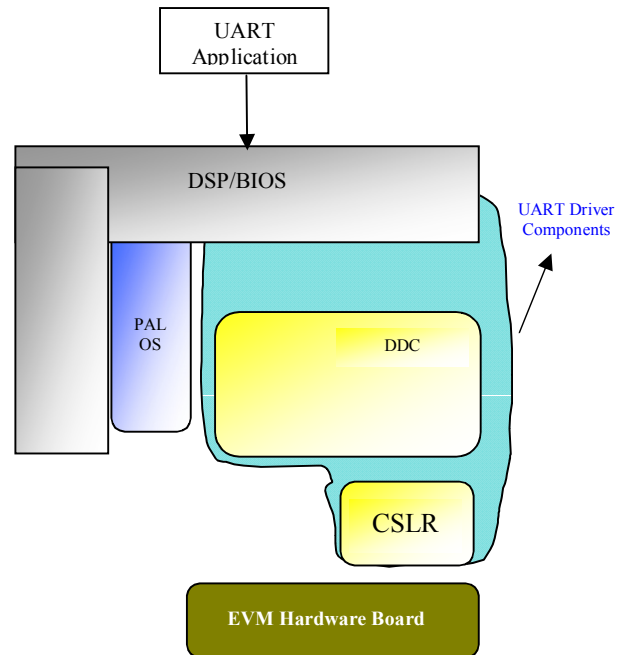

- **Multi-instantiable and re-entrant safe driver**
- **Supports H/W Flow Control**
- **Provides Synch mode of operation.**
- **Operates in Polled and Interrupts**

DSP/BIOS UART DEVICE DRIVER DRIVER DATASHEET



Description

For hardware, software & S/W components used refer to the release notes in the root of the installation directory.

Capabilities

The UART DSP/BIOS device driver adopts a scalable architecture that eases customization/extension

- Isolates H/W and OS Accesses, Easy to maintain & re-target to new platforms
- Can stack custom-functions along control/data-path to realize “driver filters”
- Supports Multiple Instances

The DSP/BIOS driver APIs supported follow the general call sequence depicted in figure below



For easy and quick reconfiguration of driver, all its statically configurable parameters have been isolated into a single file -- <uart/src/ddc_uart.c>.

The driver is constituted of following sub components:

- UART IOM – Application facing, OS Specific Adaptation of UART Device Driver
- UART DDC – OS Independent part of UART Driver Core
- System components – PALOS: DSP/BIOS Abstraction, CSLR: Non-UART low-level h/w register overlays such as INTC, DMA, CHIP and generic macros.

The following table gives a quick overview of the supported API services.

uart_mdBindDev	Create (and initialize) a given Uart driver (instance)
uart_mdCreateChan	Create a particular channel for the instance of the driver
uart_mdSubmitChan	For data transaction (for both read/write)(Supports only one transaction at a time) as well as supports the abort and flush .Abort cancels all the io of the instance of the port whereas Flush cancels the io of the read channel of the particular instance.
uart_mdControlChan	Ioctl interface. Ioctls Supported are: PSP_UART_IOCTL_SET_BAUD, PSP_UART_IOCTL_SET_STOPBITS, PSP_UART_IOCTL_SET_DATABITS, PSP_UART_IOCTL_SET_PARITY, PSP_UART_IOCTL_SET_FLOWCONTROL, PSP_UART_IOCTL_SET_TRIGGER_LEVEL, PSP_UART_IOCTL_RESET_RX_FIFO, PSP_UART_IOCTL_RESET_TX_FIFO, PSP_UART_IOCTL_CANCEL_CURRENT_IO, PSP_UART_IOCTL_GET_STATS, PSP_UART_IOCTL_CLEAR_STATS, PSP_UART_IOCTL_MAX_IOCTL
uart_mddeleteChan	Delete a particular channel for the instance of the driver
uart_mdBindDev	Delete (and de-initialize) a given Uart driver (instance)



Driver Performance Characteristics

For DM648/C6452 UART driver

UART DEVICE DRIVER SUB-COMPONENT	PROGRAM MEMORY (IN BYTES)	DATA MEMORY (IN BYTES)		
		MEMORY TYPE		TOTAL (CODE+DATA)
		INITIALIZED	UN INITIALIZED	
<uart/dda>	2016	338	248	2602
<uart/ddc>	8216	92	4064	12372
Total	10232	430	4312	14974

- UART Components Total Memory for DM648/C6452 (Code & Data): **14974** Bytes

For DM6437/C6424 UART driver

UART DEVICE DRIVER SUB-COMPONENT	PROGRAM MEMORY (IN BYTES)	DATA MEMORY (IN BYTES)		
		MEMORY TYPE		TOTAL (CODE+DATA)
		INITIALIZED	UN INITIALIZED	
<uart/dda>	2016	338	332	2686
<uart/ddc>	8216	92	5948	14256
Total	10232	430	4312	16942

- UART Components Total Memory for DM6437/C6424 (Code & Data): **16942** Bytes



Driver Profiling Characteristics

Polled Mode								
API Profiled	Trial-1	Trial-2	Trial-3	Trial-4	Trial-5	Average (uSecs)	MAX (uSecs)	MIN (uSecs)
DEV_createDevice	120.00	95.00	95.00	95.00	95.00	100.00	120.00	95.00
GIO_create	15.00	10.00	10.00	10.00	10.00	11.00	15.00	10.00
GIO_write	346.00	389	428.00	467.00	509.00	427.80	509.00	346.00
GIO_control	53175.00	51150.00	51165.00	52166.00	53203.00	52171.80	53203.00	51150.00
GIO_delete	7.00	5.00	5.00	5.00	5.00	5.40	7.00	5.00
DEV_deleteDevice	2.00	1.00	1.00	1.00	1.00	1.20	2.00	1.00
Interrupt Mode								
API Profiled	Trial-1	Trial-2	Trial-3	Trial-4	Trial-5	Average (uSecs)	MAX (uSecs)	MIN (uSecs)
DEV_createDevice	98.00	96.00	96.00	96.00	96.00	96.40	98.00	96.00
GIO_create	11.00	10.00	11.00	11.00	10.00	10.60	11.00	10.00
GIO_write	6.00	3.00	3.00	3.00	3.00	3.60	6.00	3.00
GIO_control	49516.00	55146.00	53175.00	54174.00	51168.00	52635.80	55146.00	49516.00
GIO_delete	5.00	5.00	5.00	5.00	5.00	5.00	5.00	5.00
DEV_deleteDevice	1.00	1.00	1.00	1.00	1.00	1.00	1.00	1.00

GIO_read in not profiled because it depends on user input to tera-term



Driver Performance Characteristics

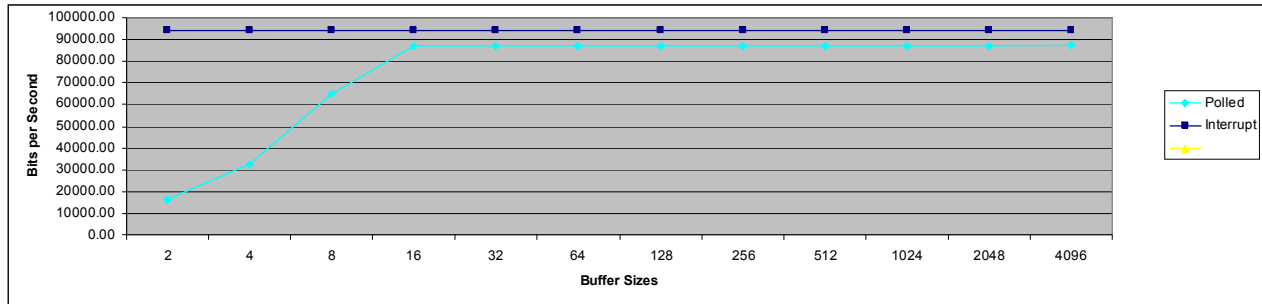

Test Setup Information	Packet Size (in bytes)	Polled			Interrupt		
		Bits/Sec	Pkts	Duration	Bits/Sec	Pkts	Duration
	2	16266.67	61000	60	94334.13	353753	60
	4	32533.87	61001	60	94363.73	176932	60
API Interface : GIO_Write	8	65067.73	61001	60	94349.87	88453	60
	16	86756.27	40667	60	94350.93	44227	60
	32	86758.40	20334	60	94344.53	22112	60
	64	86758.40	10167	60	94344.53	11056	60
	128	86766.93	5084	60	94344.53	5528	60
	256	86766.93	2542	60	94344.53	2764	60
	512	86766.93	1271	60	94344.53	1382	60
	1024	86835.20	636	60	94344.53	691	60
	2048	86835.20	318	60	94481.07	346	60
	4096	87381.33	160	60	94481.07	173	60

Comments:
Baud rate is configured to be 115200
System is configured as cache enabled
FIFO is enabled. Tx trigger level is 14 bytes.
Stop bit is configured to be 1.
Parity is disabled.
Flow control is disabled.
UART_TPOLL_MSECS is defined as 1

IMPORTANT NOTICE

Texas Instruments Incorporated and its subsidiaries (TI) reserve the right to make corrections, modifications, enhancements, improvements, and other changes to its products and services at any time and to discontinue any product or service without notice. Customers should obtain the latest relevant information before placing orders and should verify that such information is current and complete. All products are sold subject to TI's terms and conditions of sale supplied at the time of order acknowledgment.

TI warrants performance of its hardware products to the specifications applicable at the time of sale in accordance with TI's standard warranty. Testing and other quality control techniques are used to the extent TI deems necessary to support this warranty. Except where mandated by government requirements, testing of all parameters of each product is not necessarily performed.

TI assumes no liability for applications assistance or customer product design. Customers are responsible for their products and applications using TI components. To minimize the risks associated with customer products and applications, customers should provide adequate design and operating safeguards.

TI does not warrant or represent that any license, either express or implied, is granted under any TI patent right, copyright, mask work right, or other TI intellectual property right relating to any combination, machine, or process in which TI products or services are used. Information published by TI regarding third-party products or services does not constitute a license from TI to use such products or services or a warranty or endorsement thereof. Use of such information may require a license from a third party under the patents or other intellectual property of the third party, or a license from TI under the patents or other intellectual property of TI.

Reproduction of information in TI data books or data sheets is permissible only if reproduction is without alteration and is accompanied by all associated warranties, conditions, limitations, and notices. Reproduction of this information with alteration is an unfair and deceptive business practice. TI is not responsible or liable for such altered documentation.

Resale of TI products or services with statements different from or beyond the parameters stated by TI for that product or service voids all express and any implied warranties for the associated TI product or service and is an unfair and deceptive business practice. TI is not responsible or liable for any such statements.

Copyright © 2006 Texas Instruments Incorporated. All rights reserved.

Information in this document is subject to change without notice. Texas Instruments may have pending patent applications, trademarks, copyrights, or other intellectual property rights covering matter in this document. The furnishing of this documents is given for usage with Texas Instruments products only and does not give you any license to the intellectual property that might be contained within this document. Texas Instruments makes no implied or expressed warranties in this document and is not responsible for the products based from this document. This information applies to a product under development. Its characteristics and specifications are subject to change without notice. Texas Instruments assumes no obligation regarding future manufacturing unless otherwise agreed to in writing.