

eZ-FET lite Revision 1.10 User's Guide

Introduction

The eZ-FET lite is a low cost USB-based on-board emulation solution for MSP430 microcontrollers. It allows direct interfacing to a PC for easy programming, debugging, and evaluation and provides a USB-to-UART bridge for serial connection to the target microcontroller.

The eZ-FET lite on-board emulation is supported by the MSP430 DLL and can be used with IAR Embedded Workbench™ for MSP430 Integrated Development Environment (IDE) or Code Composer Studio™ (CCS) IDE to write, download, and debug applications. Other tools supporting the eZ-FET on-board emulation are the MSP430Flasher, Elprotronic's FET-Pro430, mspgcc and Energia.

The debugger is unobtrusive, allowing the user to run an application at full speed with hardware breakpoints and single stepping available while consuming no extra hardware resources.

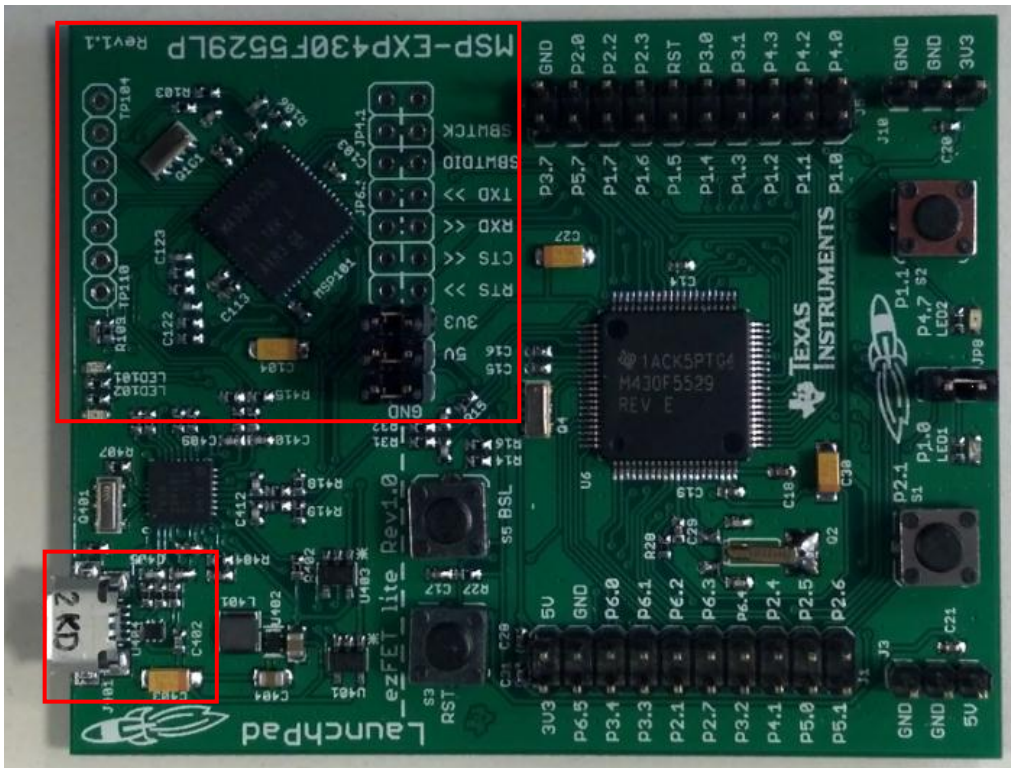

Figure 1: eZ-FET lite on-board emulation (marked red) on MSP-EXP430F5529LP Experimenter's Board

Features

- USB debugging and programming interface featuring a driverless installation
- Application UART serial communication with up to 1MBaud
- Green and red LED for visual feedback
- Field-updateable firmware
- Supports all MSP430 devices

Hardware and Software Requirements

The following hardware and software is required to use the eZ-FET on-board emulation

- Personal computer with Windows O/S or Linux
- MSP430.DLL 3.3.0.6 or higher
- Texas Instruments Code Composer Studio 5.4 or higher
- IAR Embedded Workbench 5.50 or higher

Reference Layout PCB Overview

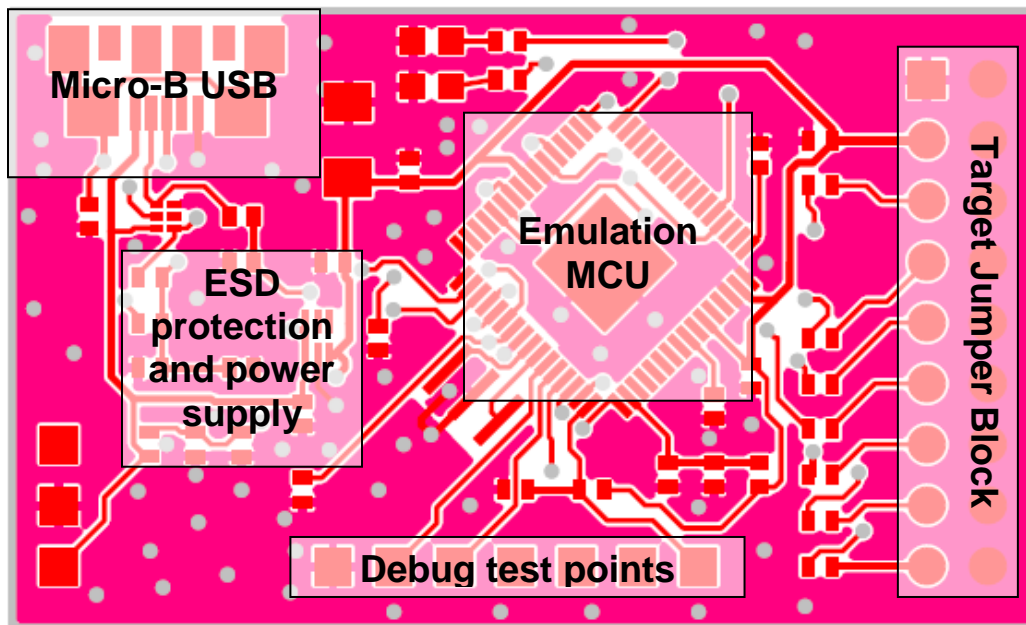

Figure 2: eZ-FET Revision 1.10 reference layout overview

Target Connector

The connection between the eZ-FET lite on-board emulation and the target microcontroller can be opened with the jumper array J101. This can be useful to connect to another target board, or when using a standalone debugger connected to the standard 14-pin header.

The jumper array can also be used to measure the power consumption of the target application. For this intention, all connections except VCC must be opened, and a multi meter can be used on the VCC jumper to measure the current of the target microcontroller and its peripherals.

The VCC jumper also must be opened if the target microcontroller is powered with an external power supply.

J101 Pin	Signal	Description
1	GND	PCB ground
3	EZFET_VCC	Target power supply voltage, defined by IC101 output voltage
5	T_TEST_TCKC	Test mode for JTAG pins or Spy-Bi-Wire test clock input during programming and test
7	T_RST_RST	Reset or Spy-Bi-Wire test data input/output during programming and test
9	T_NC_TMSC	Reserved for future expansion. Please keep in custom layouts. Will be utilized after a future firmware update.
11	T_UART_TXD	Target UART receive data input
13	T_UART_RXD	Target UART transmit data output
15	T_UART_RTS	Target UART Clear-To-Send handshake input
17	T_UART_CTS	Target UART Ready-To-Send output

Jumpers 11 and 13 connect the UART interface of the emulator to the target device pins. For higher baud rates it is recommended to also connect the handshake lines on jumpers 15 and 17 and make sure the target application code uses them appropriately.

LED Signal Play

The LED signal play is compatible with the MSP-FET430UIF and gives information about the internal status of the device.

Green LED (Power)	Red LED (Mode)	Description
OFF	OFF	eZ-FET is not connected to PC. eZ-FET is not ready (e.g. after update). Re-connect needed.
ON	OFF	eZ-FET is connected and ready. eZ-FET interface is not opened by IDE.
ON	ON	eZ-FET interface is used by IDE, but no data transfer takes place.
ON	Blinking	eZ-FET is in action: data transfer between eZ-FET and IDE takes place.
OFF	ON	Severe ERROR occurred. Re-connect eZ-FET, if doesn't help – send for repair.
Blinking by turns with red	Blinking by turns with green	Don't touch eZ-FET! Critical update is running on eZ-FET, wait until finished.

Using the UART backchannel

The UART backchannel has been developed such that it can operate fully independent from the debugger channel. When the eZ-FET lite is plugged into a Windows computer, two additional virtual COM ports will be shown in the Device Manager. The UART backchannel is accessible through the "MSP Application UART 1" virtual COM port.

Any program that is able to generate serial data (e.g. a hyper terminal tool) can open this port and send data to the target microcontroller. Please configure the virtual COM port to use 8 data bits, no parity and one stop bit (8-N-1).

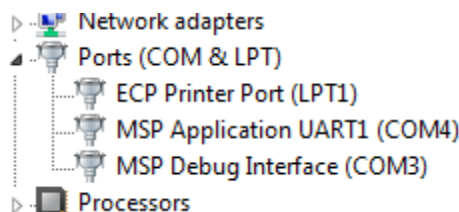

Figure 3: Device Manager with eZ-FET lite ports

In order to successfully communicate with the target microcontroller, the baud rate setting on the computer side has to match the baud rate settings of the target microcontroller.

Specification

		eZ-FET lite	Note
Electrical	Power supply	2.8V – 3.6V	Fixed voltage, supplied through LDO IC101
	Target current	75mA max.	eZ-FET lite USB descriptor requests max. 100mA from USB bus
	Target current overprotection	Not included	
Debug	Method	Spy-bi-Wire	
	Speed	200-700kHz	Configurable through MSP430.DLL
UART Backchannel	Supported baud rates w/o handshake	110/300/1200/2400 baud	Requires min. 32kHz target MCU speed
		4800/9600/19200/38400/ 57600 baud	Requires min. 1MHz target MCU speed
		115200/230400 baud	Requires min. 8MHz target MCU speed
	Supported baud rates w/ handshake	110/300/1200/2400/4800 baud	Requires min. 32kHz target MCU speed
		9600/19200/ 38400/ 57600/115200 baud	Requires min. 1MHz target MCU speed
		230400/460800 baud	Requires min. 8MHz target MCU speed

Supported Devices

Texas Instruments offers a wide range of MSP430 devices that are compatible with the eZ-FET. The following table shows the devices that have been tested.

Part Number	Family	Description
MSP430F2274		
CC430F6147		
MSP430F4152		

MSP430F5529		
MSP430AFE253		
MSP430G2452		
MSP430F6736		
MSP430F5438		
MSP430F6638		
MSP430FR5969		
MSP430F6659		
MSP430F5171		
MSP430F5341		
MSP430F5342		
MSP430F5419		
MSP430F5526		
MSP430F5528		

FAQ

Q: My MSP430 target device is not listed in the table of supported device. What should I do?

A: The table only lists the devices that have been tested with the eZ-FET lite at the time of publication. There is a good chance that the eZ-FET works with the MSP430 target device. If you experience any problems, please contact us through the E2E forum on www.ti.com.

Q: I cannot communicate with the target microcontroller through the UART backchannel.

A: Several things need to be considered for a successful serial communication: matching baud rate settings on both computer and target side, the use of handshake lines (especially for higher baud rates), and the correct clock frequency of the target microcontroller. If the target microcontroller's clock frequency does not match the value used to calculate the UART settings, communication won't be successful. If in doubt, measure the baud rate on the TXD and RXD lines by sending alternating bit patterns from either side. A small deviation is acceptable, but if the error is large, send and transmit will most likely not be possible.

Q: I would like to build my own tool using the eZ-FET lite. Where can I find more information?

A: Please have a look into the official eZ-FET lite release package. The folders "Firmware" and "Production Setup" include both the binary files required to program the eZ-FET lite microcontroller as well as a graphical environment that can be used to test the eZ-FET lite hardware before programming it with production firmware.

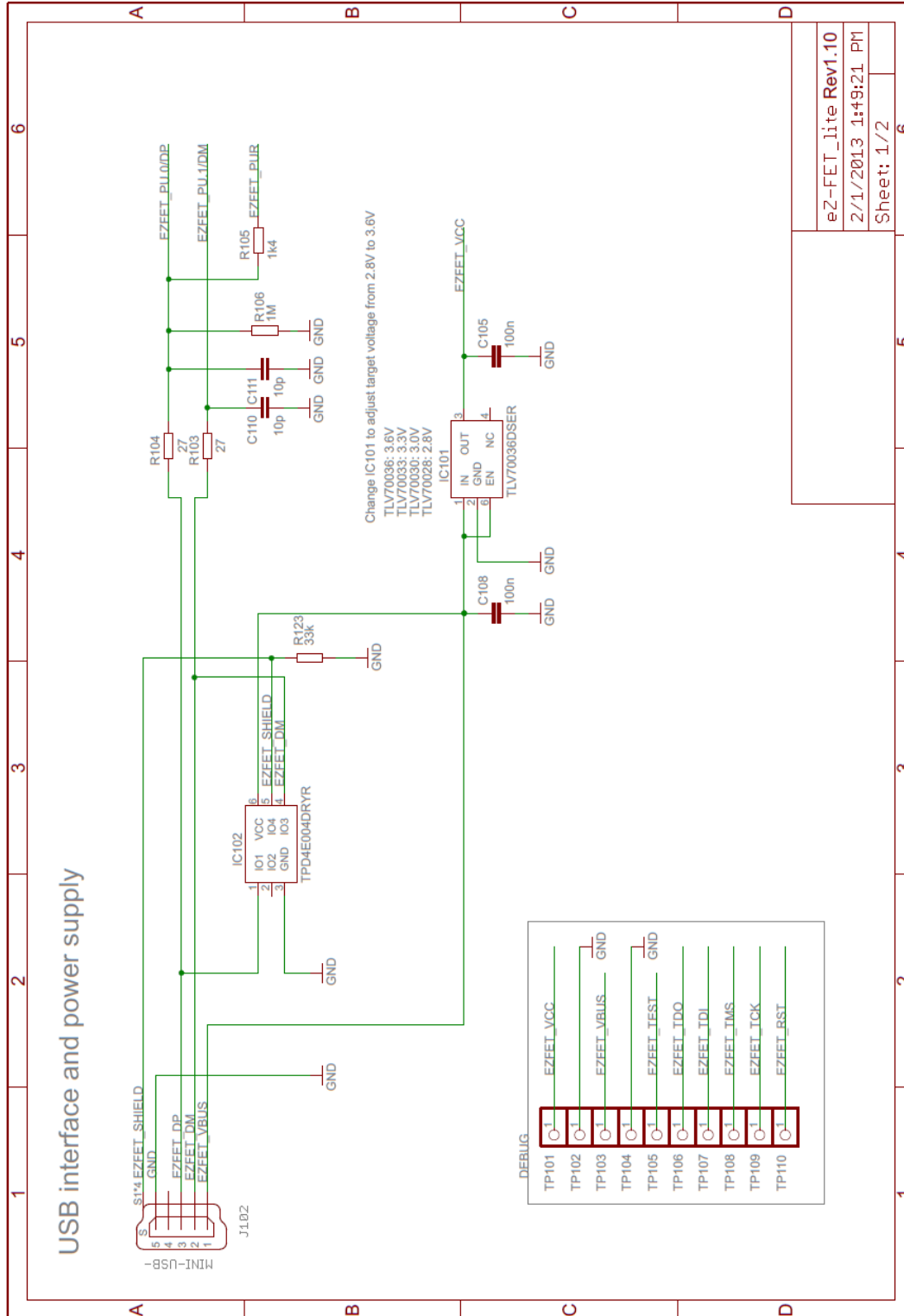
Schematic

eZ-FET_lite Rev1.10
2/1/2013 1:49:21 PM
Sheet: 1/2

eZ-FET lite Revision 1.10 User's Guide

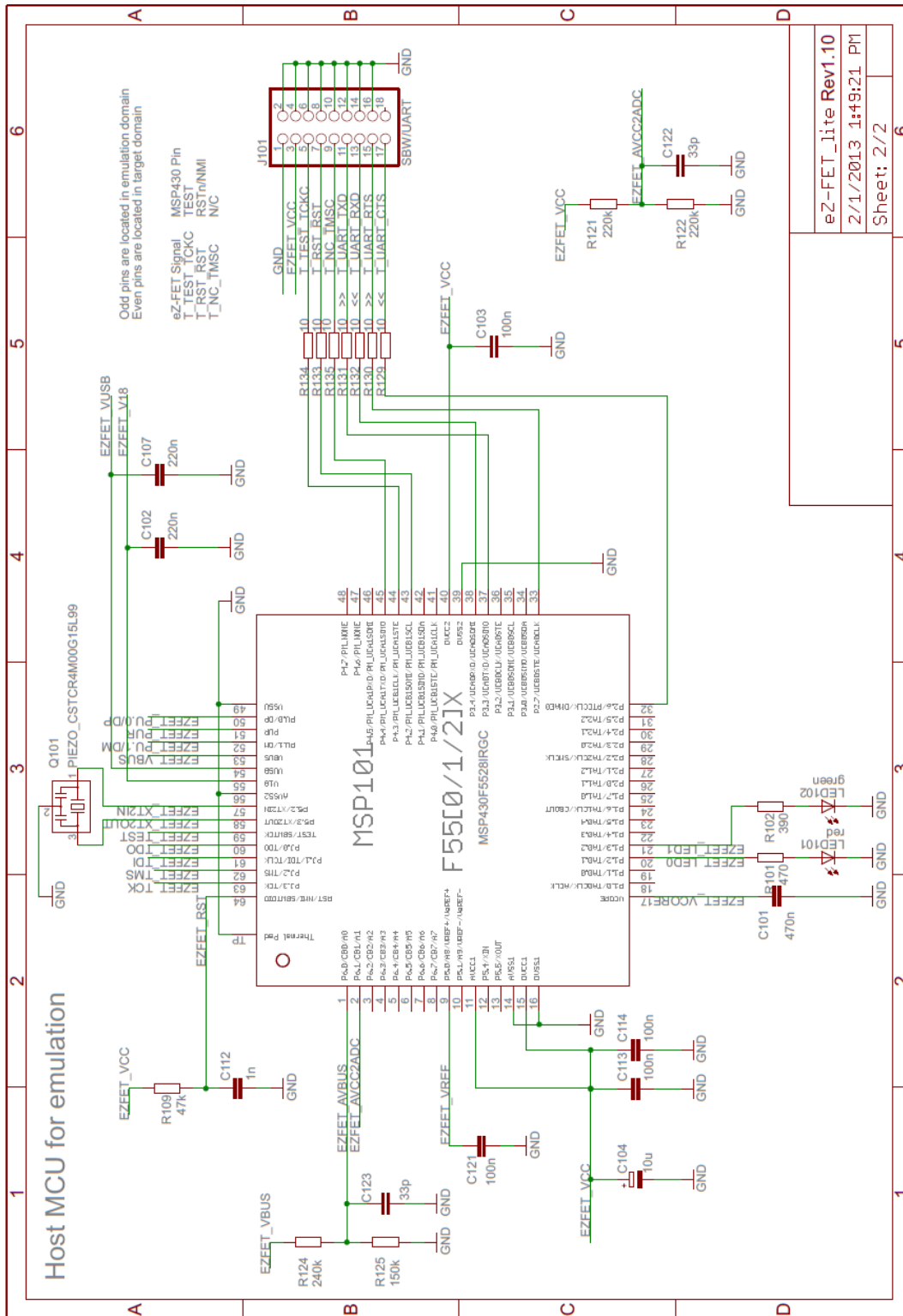

eZ-FET_lite Rev1.10
 2/1/2013 1:49:21 PM
 Sheet: 2/2

Bill of Material

Item	Qty	Reference	Manufacturer	Part Number	Value
1	1	C101	TDK	C1005X5R1C474K	470n
2	1	C102	TDK	C1005X5R1C224K	220n
3	1	C103	TDK	C1005X5R1A104M	100n
4	1	C104	Nichicon	F931A106MAA	10u
5	1	C105	TDK	C1005X5R1A104M	100n
6	1	C107	TDK	C1005X5R1C224K	220n
7	1	C108	TDK	C1005X5R1A104M	100n
8	1	C110	TDK	C1005C0G1H100D	10p
9	1	C111	TDK	C1005C0G1H100D	10p
10	1	C112	TDK	C1005X7R1H102K	1n
11	1	C113	TDK	C1005X5R1A104M	100n
12	1	C114	TDK	C1005X5R1A104M	100n
13	1	C121	TDK	C1005X5R1A104M	100n
14	1	C122	TDK	C1005C0G1H330J	33p
15	1	C123	TDK	C1005C0G1H330J	33p
16	1	IC101	TI	TLV70036DSER	TLV70036DSER
17	1	IC102	TI	TPD4E004DRYR	TPD4E004DRYR
18	1	J101	Sullins	PEC09DAAN	SBW/UART
19	1	J102	Hirose Electrical Co	ZX62R-B-5P	ZX62R-B-5P
20	1	LED101	Lite-On	LTST-C190CKT	Red
21	1	LED102	Lite-On	LTST-C190GKT	Green
22	1	MSP101	TI	MSP430F5528IRGC	MSP430F5528IRGC PIEZO_CSTCR4M00G15L9
23	1	Q101	Murata	CSTCR4M00G15L99	9
24	1	R101	Yageo	RC0402FR-07470RL	470
25	1	R102	Yageo	RC0402FR-07390RL	390
26	1	R103	Yageo	RC0402JR-0727RL	27
27	1	R104	Yageo	RC0402JR-0727RL CRCW04021K40FKE	27
28	1	R105	Vishay Dale	D	1k4
29	1	R106	Yageo	RC0402FR-071ML	1M
30	1	R109	Yageo	RC0402FR-0747KL	47k
31	1	R121	Yageo	RC0402FR-07220KL	220k
32	1	R122	Yageo	RC0402FR-07220KL	220k
33	1	R123	Yageo	RC0402FR-071ML	33k
34	1	R124	Yageo	RC0402FR-07240KL	240k
35	1	R125	Yageo	RC0402FR-07150KL	150k
36	1	R129	Yageo	RC0402FR-0710RL	10

37	1	R130	Yageo	RC0402FR-0710RL	10
38	1	R131	Yageo	RC0402FR-0710RL	10
39	1	R132	Yageo	RC0402FR-0710RL	10
40	1	R133	Yageo	RC0402FR-0710RL	10
41	1	R134	Yageo	RC0402FR-0710RL	10
42	1	R135	Yageo	RC0402FR-0710RL	10

Known Issues

1. USB suspend power down support not implemented in emulator firmware.
Applies to DLL3.3.0.6.

Revision History

Date	Description
04/16/2013	Initial version
04/18/2013	Added Known Issues chapter